

PTA/PTL/PTS series

Ordering code

PTL 6 01 A □ □
 ① ② ③ ④ ⑤ ⑥

① Model	② Port size	③ Thread connection	④ Control method	⑤ Standard color	⑥ Thread type
PTL: Speed controller (Push lock) 	4: Φ4mm 6: Φ6mm 8: Φ8mm 10: Φ10mm 12: Φ12mm	M5: M5X0.8 01: 1/8" 02: 1/4" 03: 3/8" 04: 1/2"	A: Meter-out Handle marking "A" Controlled flow Free flow	Standard color: Specification Blank: Gray Release button: Gray Body: Gray	Blank: PT
PTS: Push-lock universal speed controller 			B: Meter-in Handle marking "B" Free flow Controlled flow	D: Black Release button: Black Body: Black	

PTA 6 □

① ② ③

① Model	② Port size	③ Standard color
PTA: Straight speed controller 	4: Φ4mm 6: Φ6mm 8: Φ8mm 10: Φ10mm 12: Φ12mm	Standard color: Specification Blank: Gray Release button: Gray Body: Gray D: Black Release button: Black Body: Black

Product feature

1. Compare with standard speed controller, smaller size, lighter weight, suitable for more occasions.
2. Effectively control the action speed and the pressure signal transmission from pneumatic device.
3. Simple push-lock, operation.
4. Adjust quickly, easily and accurately.
5. Excellent flow rate characteristic, high sensitivity and easy to adjust.
6. Options of Meter-out and meter-in, applicable for every type actuator.
7. Effectively prevent from corrosion and pollution by nickel plated brass.
8. The sealant being coated on threaded portion can ensure no leakage of the threaded connection part.
9. 360-degree adjustable tubing for universal speed controller(PTS)

Specification

Operating pressure range	0~10kgf/cm ² (0~1.0MPa)
Negative pressure	-750mmHg(10Torr)
Proof pressure	1.5MPa
Ambient and fluid temperature (°C)	-20~70
Applicable tubing	Soft nylon or polyurethane
Color	Grey/black

Table for interface port and tube O.D.

Product series	Thread type	Port size				
		Φ4	Φ6	Φ8	Φ10	Φ12
PTA	-	●	●	●	●	●
	1/8"		●	●	●	
PTL	1/4"		●	●	●	
	3/8"		●	●	●	●
	1/2"			●	●	●
PTS	M5	●				
	1/8"		●	●		
	1/4"		●	●	●	
	3/8"				●	●
	1/2"					●

Symbol

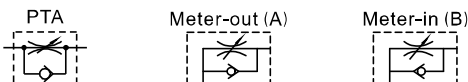

Inner structure

PTA Series

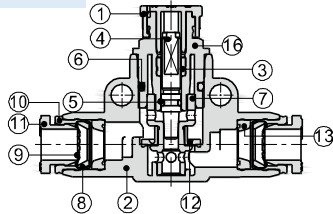

PTL Series

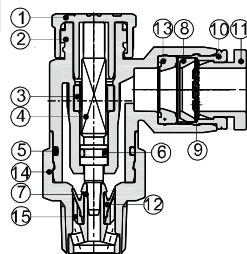

PTS Series

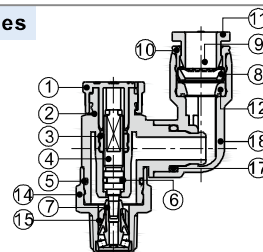

NO.	Name	Material	NO.	Name	Material	NO.	Name	Material
1	Adjusting cap	POM	7	Throttling sleeve	Aluminum alloy	13	O-ring	NBR
2	Plastic body	PBT	8	Locating seat	POM	14	stud	Brass
3	Locating ring	Aluminum alloy	9	Spring gasket	Stainless steel	15	Holder	PBT
4	Throttling column	Brass/Aluminum alloy	10	Locating ring	Aluminum alloy	16	Throttling body	PBT
5	O-ring	NBR	11	Plastic interface	POM	17	O-ring	NBR
6	O-ring	NBR	12	O-ring	NBR	18	Plastic body	PBT

PTA/PTL/PTS series

Dimensions

PTA Series

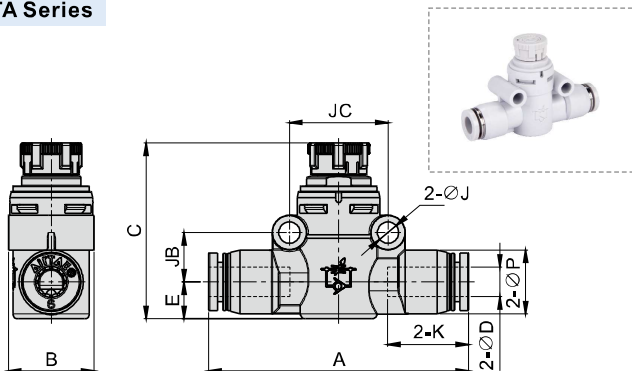

PTL Series

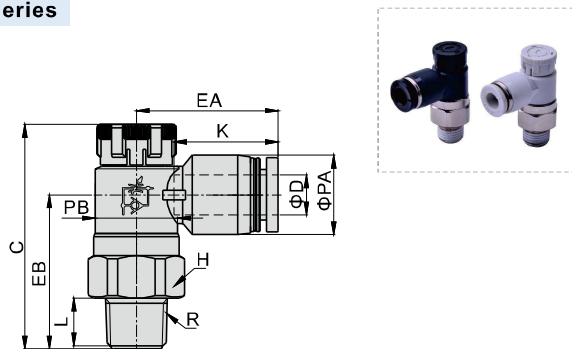

Model\Item [Note1]	ΦD	A	B	C		ΦP	E	K	ΦJ	JB	JC	Weight (g)
				Pull	Push							
PTA4	4	41	12	27	25.5	9.5	6	14	3.2	6	14	5.4
PTA6	6	52.5	17.5	37	35.5	13	7.5	16.5	4.3	10	20	13.2
PTA8	8	59.5	18.5	41	39.5	15	8.5	18.5	4.3	10	22	17.8
PTA10	10	69	22	47	49.5	18	10.5	21	4.3	13	26	30
PTA12	12	78.5	26.5	53	51.5	21.5	12	23	4.3	14.5	32	50

Model\Item [Note1]	ΦD	R	ΦPA	ΦPB	L	C		K	EA	EB	H opposite side	Weight (g)
						Pull	Push					
PTL601□	6	1/8"	12.5	13	8.5	36	34.5	16.5	22.5	23.5	14	12.5
PTL602□		1/4"	12.5	16.5	11	40.5	39	16.5	24	28	17	19.5
PTL603□		3/8"	12.5	19	12	44	42.5	16.5	25.5	31	19	28.5
PTL801□	8	1/8"	15	13	8.5	36	34.5	18.5	24.5	22.5	14	13
PTL802□		1/4"	15	16.5	11	40.5	39	18.5	26	27	17	20.5
PTL803□		3/8"	15	19	12	44	42.5	18.5	27	30	19	29
PTL804□	1/2"	15	24	15	52.5	51	18.5	29.5	37.5	24	49	
PTL1002□	10	1/4"	18	16.5	11	40.5	39	21	31	26	17	22
PTL1003□		3/8"	18	19	12	44	42.5	21	29	29	19	30.5
PTL1004□		1/2"	18	24	15	52.5	51	21	31.5	36.5	24	50.5
PTL1203□	12	3/8"	21	19	12	44	42.5	23	34.5	28	19	32.5
PTL1204□		1/2"	21	24	15	52.5	51	23	34	36	24	53

PTS Series

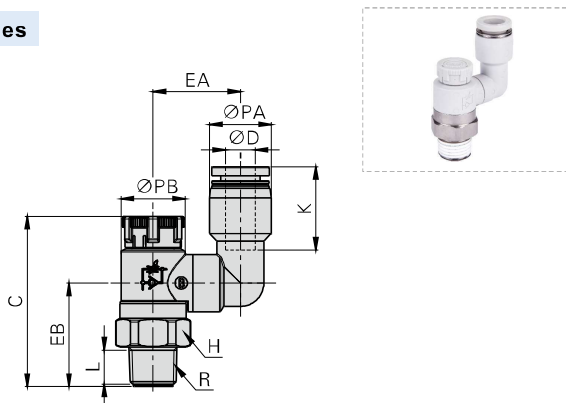

Model\Item [Note1]	ΦD	R	ΦPA	ΦPB	L	C		K	EA	EB	H opposite side	Weight (g)
						Pull	Push					
PTS4M5□	4	M5×0.8	9	9	3.5	29.5	28	14	13	19	9	7
PTS601□	6	1/8"	12.5	13	7.5	36	34.5	17	17.5	23.5	14	14
PTS602□		1/4"	12.5	13	10	40.5	39	17	20	28	17	21
PTS801□	8	1/8"	15	16.5	7.5	36	34.5	18.5	17.5	22.5	14	16
PTS802□		1/4"	15	16.5	10	40.5	39	18.5	20	27	17	23.5
PTS1002□	10	1/4"	18	19	10	40.5	39	21	21.5	26	26	22.5
PTS1003□		3/8"	18	19	11	44	42.5	21	23.5	29	29	31
PTS1203□	12	3/8"	21	24	11	44	42.5	23	25	28	19	36
PTS1204□		1/2"	21	24	14	52.5	51	23	26.5	36	24	56

[Note1] "□" stands for A or B. A indicates meter-out type while B indicates meter-in type. The two types are with the same overall dimension.

[Note1] "□" stands for A or B. A indicates meter-out type while B indicates meter-in type. The two types are with the same overall dimension.

PTA/PTL/PTS series

Flowrate characteristic

Controlled flow rate

PTL、PTS

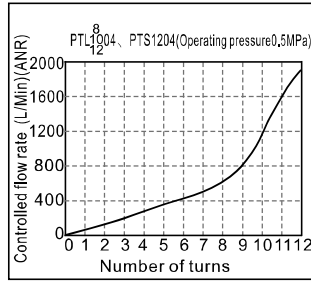
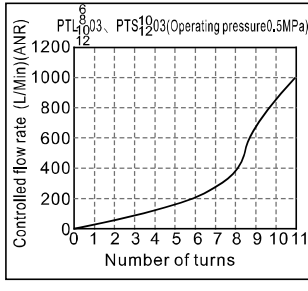
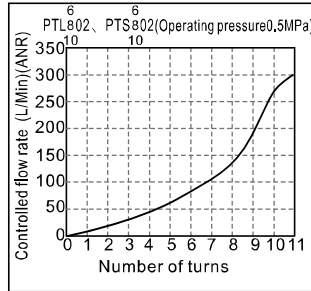
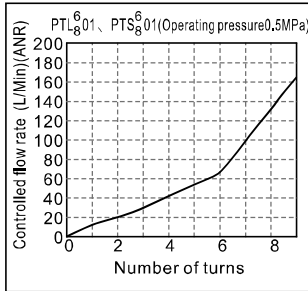
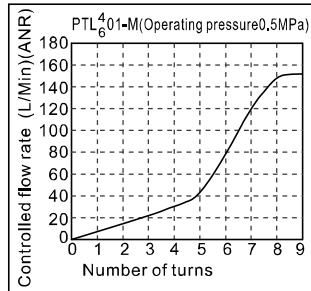
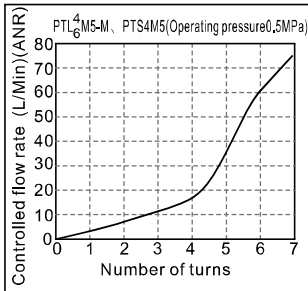

PTA

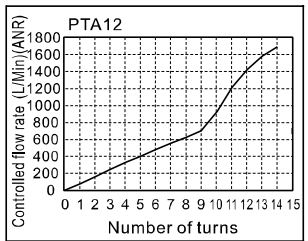
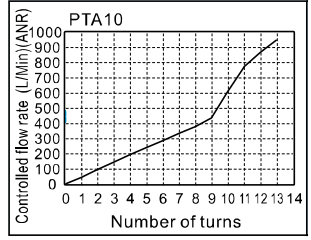
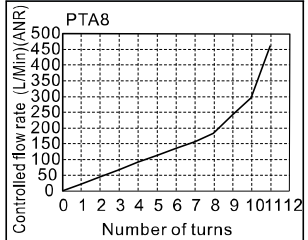
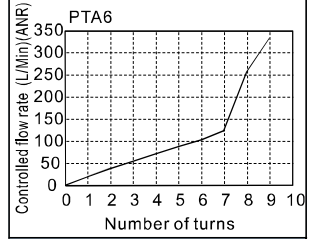
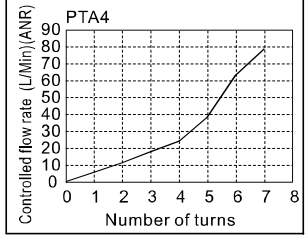

Free flow rate

PTL、PTS

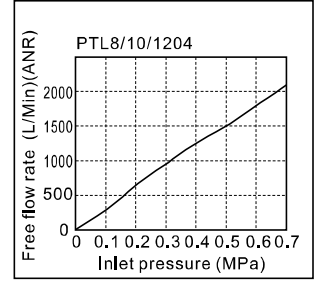
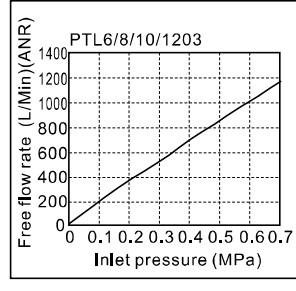
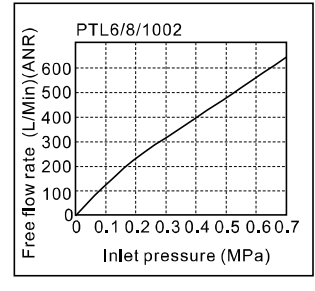
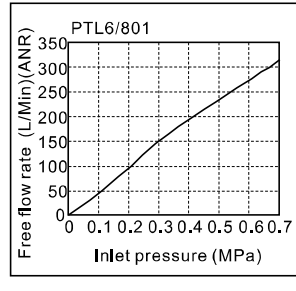
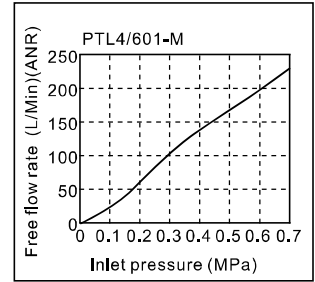
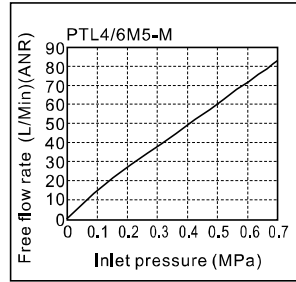

PTA

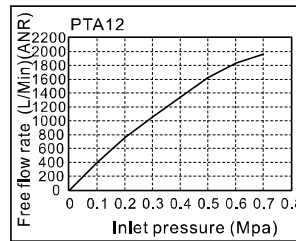
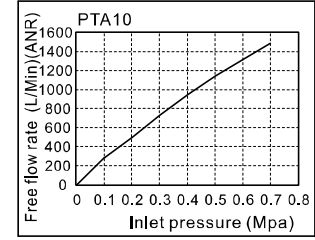
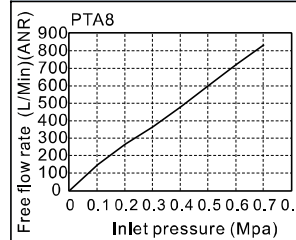
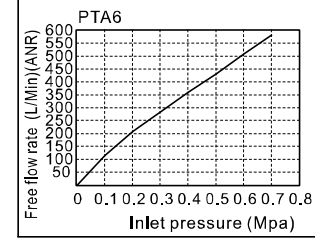
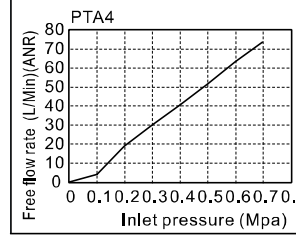

Selection, Installation and Operation

Selection

1. The speed controller has meter-out type and meter-in type:

	Working principle	Product identification
	A: Meter-out 1. The air flow is controlled from the threaded end to tubing connection end. 2. The air flow is free from the tubing connection end to the threaded end.	Handle marking "A"
	B: Meter-in 1. The air flow is free from the threaded end to tubing connection end. 2. The air flow is controlled from the tubing connection end to the threaded end.	Handle marking "B"

2. Select the different control method according to the actual requirement. The meter-out type is the first priority.

2.1. The application example of the meter-out speed controller	2.2. The application example of the meter-in speed controller

Installation

1. Installation and removal of tubing:

1.1. Installation of tubing

Grasp the tubing and slowly push it into the fitting until it comes to a stop. The tubing will be locked by the spring gasket.

1.2. Removal of tubing

Push the release button to open the spring gasket so that the tubing can be released.

Note: When remove the tubing, make sure the pressure in the tubing is Zero.

2. Mounting of the speed controller

Mount the speed controller into the inlet and outlet port of the cylinder with a wrench.

Note: Please refer to the fittings for the tightening torque and thread screw-in depth.

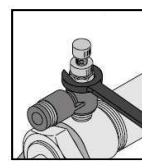
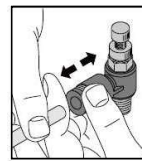
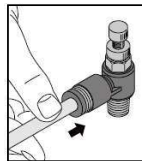

Operation

1. Adjustment of the cylinder speed

1.1. Make sure the speed controller is turned off before applying air pressure. The cylinder may fly out due to the high speed if the air is inlet when the speed controller is turned on.

1.2. Adjust the speed by opening the needle slowly from the fully closed state. When a needle valve is turned clockwise, the air flow through is reduced and the actuator speed decreases. When a needle valve is turned counter-clockwise, the air flow through is increased and the actuator speed increases.

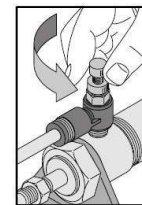
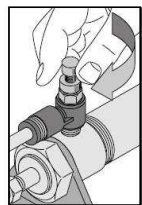

2. Operation of the speed controller

2.1. Do not use tools such as pliers to rotate the handle. Do not apply excessive force or shock when the needle is at the place of top or bottom. It can cause damage or air leakage.

2.2. A certain amount of leakage is allowed in the closed state of the speed controller. It is not designed for the use as stop valve with zero air leakage.